



# STRATEGIC RESEARCH PLAN

Utah Lake Water Quality Study  
Science Panel Webshop  
March 19-20, 2020

# GOALS

- Review Research Plan Status and Process to Finalize
- Review Research Priorities and Identify RFPs
- Complete RFP Identification
- Draft RFPs

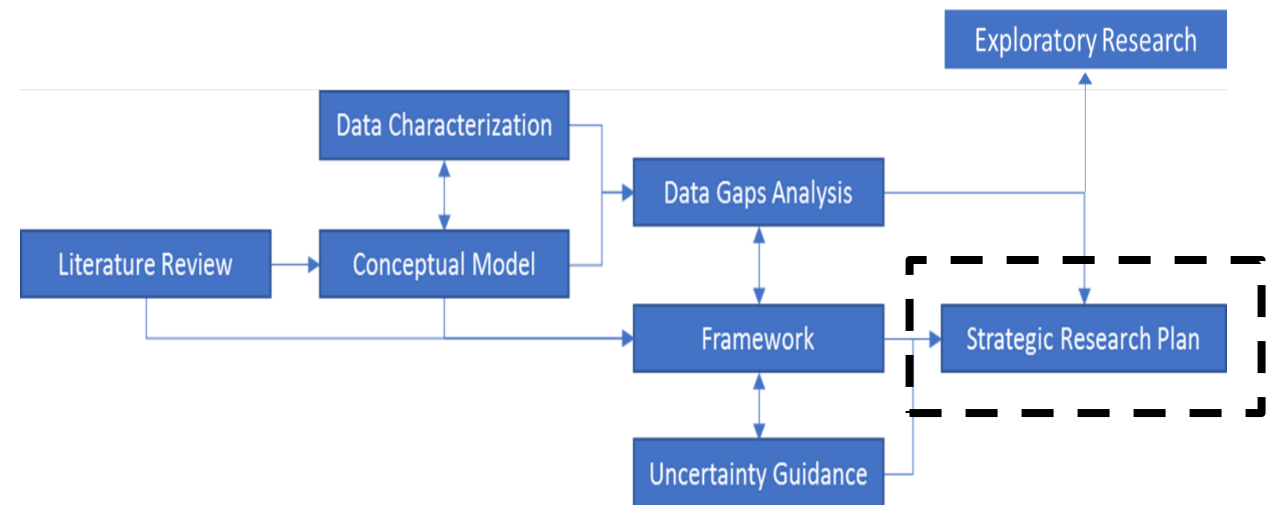

# RESEARCH PLAN STATUS

- We drafted introductory materials
- Mapped needs to knowledge
- Laid out research priorities
- Skeleton of RFPs

## Utah Lake Water Quality Study— Strategic Research Plan

**DRAFT**

February 18, 2020  
Version 3.0

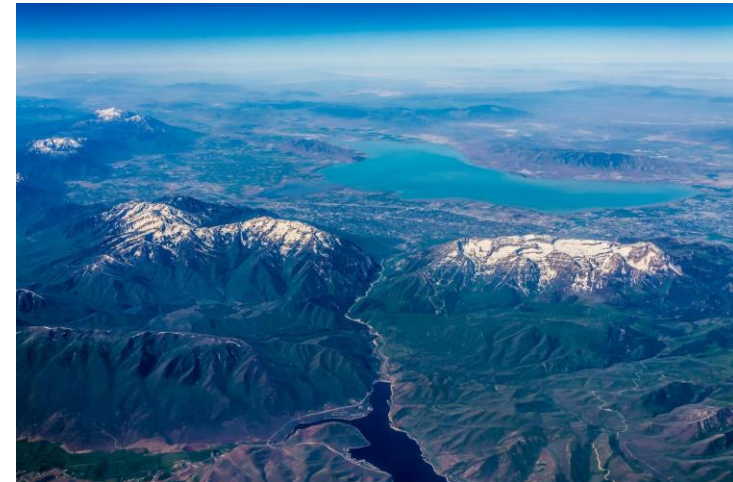

### PRESENTED TO

Utah Department of Environmental  
Quality  
Division of Water Quality  
PO Box 144870  
Salt Lake City, UT 84114

### PREPARED BY

Tetra Tech  
1 Park Drive, Suite 200  
Research Triangle Park, NC 2709

# PROCESS TO FINALIZE

- Complete identifying projects (today)
- Draft RFP elements (today)
- We fill out RFP components – iterate with you
  - SP Finalizes RFPs (April)
  - SP Finalizes SRP (May/June)
- Complete RFPs/SRP
  - RFPs to SC for approval (April/May)
  - RFPs out for bid (April/May)
  - SRP to SC for approval (May/June)

## Utah Lake Water Quality Study— Strategic Research Plan

### DRAFT

February 18, 2020  
Version 3.0

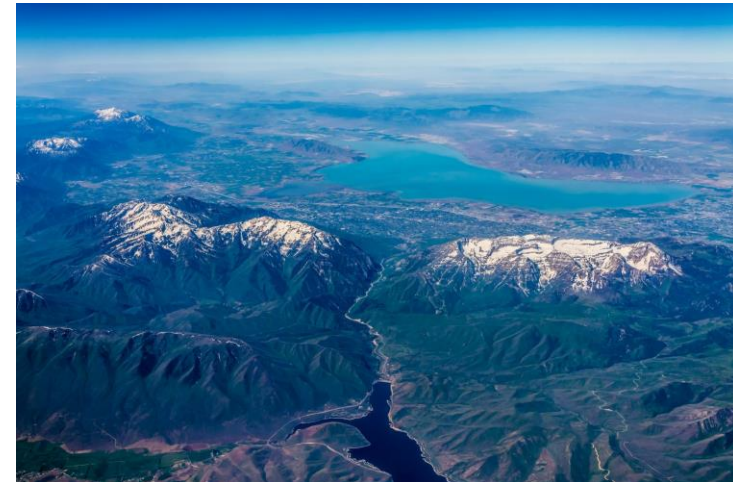

#### PRESENTED TO

Utah Department of Environmental  
Quality  
Division of Water Quality  
PO Box 144870  
Salt Lake City, UT 84114

#### PREPARED BY

Tetra Tech  
1 Park Drive, Suite 200  
Research Triangle Park, NC 2709

# PRIORITIZATION REVIEW

- Started with 13 ideas from 2019 that were not funded
- December – Two groups, modified Delphi ranking, introduced 6 new ideas
- January – Ranked all research ideas
- Straight average
- Are we okay with this ordering?
- Do we need to combine any?

Research ideas		Mean Ranking - Feb 2020
1	How large is internal vs external loading (how long would recovery take?)	2.3
2	Sediment budgets (C, N, and P; nutrient flux chambers)	3.6
3	Calcite scavenging (how bioavailable is SRP – does bioassay address?)	4.3
4	Adding modules to the WQ models (sediment diagenesis, calcite scavenging)	4.3
5	Carp effects on nutrient cycling	7.3
6	Lake level (effect on macrophytes)	9.2
7	Bioassays that incorporate sediment (next phase mesocosms)	9.4
8	Macrophyte recovery potential (Provo Bay demo)	10.0
9	Lake-level effects on biogeochemistry and nutrient cycling	10.2
10	Environmental controls on toxin production	11.1
11	Turbidity effect on primary producers	11.2
12	Resuspension rates from bioturbation	11.7
13	Carp effects on zooplankton (and does this influence algal response)	11.8
14	Carp effects on macrophytes	12.1
15	Toxin Production and N Species	13.7
16	Recreational surveys	13.8
17	Macrophyte role (to biogeochemistry)	14.0
18	Additional atmospheric deposition data	14.6
19	Alternative models (PCLake – cyano/macrophyte state change)	14.9

# IDENTIFYING RFPS

- Hopefully you had a chance to review
- Builds from Draft SRP, 1: 1 call and March 3 conference call
- Maps the summary of 1:1 project idea conversations to priorities
- We need to get to a comfortable set of RFPs (2-4)

## Utah Lake Water Quality Study— Strategic Research Planning Priorities and Projects

March 17, 2020  
Version 2.0

### PRESENTED TO

Utah Department of Environmental  
Quality  
Division of Water Quality  
PO Box 144870  
Salt Lake City, UT 84114

### PREPARED BY

Tetra Tech  
1 Park Drive, Suite 200  
Research Triangle Park, NC 2709

# IDENTIFYING RFPS

- Next slides
- Merge Research Priorities with RFP ideas
- We need to get to a comfortable set of RFPs (2-4)

F9/31



## *Scope of Work: Historic Trophic State and Nutrient Concentrations in the Paleo Record of Utah Lake*

### 1. Introduction

The Utah Department of Environmental Quality, Division of Water Quality (DWQ) is requesting grant proposals for technical support to conduct a paleolimnological study of Utah Lake. A Paleo experimentation was prioritized for 2019 by the Utah Lake Water Quality Study (ULWQS) Science Panel to determine the historical nutrient regime of the lake. The target completion date of this scope is January 31, 2020.

Please submit a grant proposal including a cost proposal to Emily Canton at [ercanton@utah.gov](mailto:ercanton@utah.gov) by 5:00 PM MST May 22, 2019. Proposals must be limited to 10 pages; this page limit does not include resumes and project case studies that may be included in an appendix.

### 2. Background

The Utah Division of Water Quality (DWQ) recently initiated Phase 2 of the Utah Lake Water Quality Study (ULWQS) to evaluate the effect of excess nutrients on the lake's recreational, aquatic life, and agricultural designated uses and to develop site-specific nitrogen and phosphorus water quality criteria to protect these uses. The ULWQS is guided by the Stakeholder Process (Attachment A) developed during Phase 1, which established a 16-member interest-based Steering Committee and a 10-member disciplinary-based Science Panel. The Steering Committee has charged the Science Panel with developing and answering key questions to characterize historic, current, and future nutrient conditions in Utah Lake (Attachment B). Responses to the key questions will be used by the Steering Committee to establish management goals for the lake and by the Science Panel to guide development of nutrient criteria to support those goals.

Additionally, the Science Panel must complete a significant number of tasks to achieve its purpose of guiding the development of nutrient criteria as described in Attachment C including:

- Guiding the approach for establishing nutrient criteria
- Recommending and guiding studies to fill data gaps needed to answer key questions

# INTERNAL VS EXTERNAL LOADING/SEDIMENT BUDGETS (PRIORITIES 1 AND 2)



- Consolidate our knowledge - (rates/fluxes)
  - Use an intermediate model?
- Identify gaps
- More in-situ measures?
- What are sediment conditions (Redox, pH)?

## **Research Project Idea 1: P cycling inventory, gap identification, and study ideas**

**Problem statement:** As far as we know, no one has, as of yet, compiled all the known information on P stocks and fluxes for the lake ecosystem, especially the sediments.

**Project objective:** Compile all known data on standing stock and flux rates for P in Utah Lake, using the P conceptual model or intermediate biogeochemical models (e.g., SedFlux or PHREEQ) as a beginning. Identify major gaps and uncertainties and provide example studies to fill these gaps



# INTERNAL VS EXTERNAL LOADING/SEDIMENT BUDGETS (PRIORITIES 1 AND 2)



- Consolidate our knowledge - (rates/fluxes)
  - Use an intermediate model?
- Identify gaps
- More in-situ measures?
- What are sediment conditions (Redox, pH)?

## **Research Project Idea 2: N cycling inventory, gap identification, and study ideas**

**Problem statement:** As far as we know, no one has, as of yet, compiled all the known information on N stocks and fluxes for the lake ecosystem, especially the sediments.

**Project objective:** Compile all known data on standing stock and flux rates for N in Utah Lake, using the N conceptual model or intermediate biogeochemical models (e.g., SedFlux or PHREEQ) as a beginning. Identify major gaps and uncertainties and provide example studies to fill these gaps

# CALCITE/P AVAILABILITY (PRIORITY 3)



- What is the role of calcite scavenging?
- Chemistry is complex
- Nature of binding?
- Did we learn from bioassay?
- P bioavailability is a question

## **Research Project Idea 3: Calcite binding in Utah Lake**

**Problem statement:** As far as we know, as of yet, there has not been adequate quantification of the potential or actual rate of calcite formation and P binding to calcite in Utah Lake as a specific, but important, component of the P cycle.

**Project objective:** Assemble existing data on calcite formation, its effect on P binding and review the potential modifying role of other ions in this phenomenon. Conduct lab studies using Utah Lake water to evaluate controls on P binding to calcite, the chemical nature of that binding, loss rates from the water column and permanence (fate). Combine that with field studies to evaluate specific rates of calcite binding in the water column along tributaries, from P released to the water column and subsequent loss to the sediments.

# CALCITE/P AVAILABILITY (PRIORITY 3)



- What is the role of calcite scavenging?
- Chemistry is complex
- Nature of binding?
- Did we learn from bioassay?
- P bioavailability is a question

## **Research Project Idea 4: Phosphorus bioavailability**

**Problem statement:** There appears to be a mismatch between measured phosphorus and chlorophyll yield, suggesting P is not as bioavailable as would be suggested by the soluble reactive P concentrations. While bioassays measured chlorophyll response to P, this has not been done in the context of bioavailability.

**Project objective:** Measure P bioavailability using the algal growth potential method. In brief, compare monoculture algal growth using filtered Utah Lake water compared to a stock solution of equal SRP.

# MODEL MODULES (PRIORITY 4)

- Overlaps with others – will need modules for the above
  - Need to clarify
- WASP does have sediment diagnosis
  - Whether it works/can be made to work for your needs is a question

**Research Project Idea: Not at this time**



# NITROGEN (PRIORITY 1 AND 2)



- Extension of the first topic
- What do we know of N stocks and fluxes?
- Where is deNit occurring?  
And how much?

## **Research Project Idea 5: Nitrogen cycling measures**

***Problem statement:*** Little or nothing is known about major N transformations in Utah Lake

***Project objective:*** Quantify in situ rates of N uptake, N fixation, nitrification and denitrification across the lake ecosystem (including in the water column and sediments) over time.

# LAKE LEVEL AND LITTORAL SEDIMENTS (PRIORITIES 1, 2 AND 9)

- Little known of flux to/from littoral sediments over wet/dry cycle.



## **Research Project Idea 6: Utah Lake Littoral Sediment Study**

**Problem statement:** Little or nothing is known about whether the drying and wetting of littoral sediments that occurs with lake level fluctuations represents a source or sink of N and P.

**Project objective:** Conduct laboratory and field studies of littoral sediment cores measuring the rate and N and P fluxes during wetting, drying, and rewetting periods of different lengths.

# CARBON CYCLING (PRIORITY 2)

- Also extension of above
- Many cycles depend on C
- UL is productive, but sediments are low in C; where is the C?
- Do we know enough about C cycling in UL?

## **Research Project Idea 7: Utah Lake Carbon Study**

**Problem statement:** Where is the carbon balance ending up in Utah Lake? Is water column respiration sufficient to respire autochthonous and allochthonous carbon? If not, where is the carbon going? Are nitrogen reactions carbon limited?

**Project objective:** Compile a carbon budget for Utah Lake and measure missing or undermeasured standing stocks and carbon fluxes to and from the sediments.

# MESOCOSM OPPORTUNITIES (PRIORITIES 3, 5, 6, 7, 9, 11, 13, 14, AND 17)

- Mesocosms could address many areas

- Unclear what final design of TSSD mesocosms will be (how many, where, how large, etc.)

- So may be hard to say what to do, but maybe how to do would help?

**Research Project Idea: None as of yet**





# WHICH RFPS TO PURSUE?

- Do you like any of those above?
- Are there any new ones proposed?
- Which 2-4 can we narrow it down to?
- We will turn this into full RFPs – but we need direction and help with the main elements



# RFP IDEAS

**Research Project Idea 1: P cycling inventory, gap identification, and study ideas**

**Research Project Idea 2: N cycling inventory, gap identification, and study ideas**

**Research Project Idea 3: Calcite binding in Utah Lake**

**Research Project Idea 4: Phosphorus bioavailability**

**Research Project Idea 5: Nitrogen cycling measures**

**Research Project Idea 6: Utah Lake Littoral Sediment Study**

**Research Project Idea 7: Utah Lake Carbon Study**

**Research Project Idea X: Mesocosm experiments**

# NEXT STEPS: RFP

- Which 2-4 to now develop into RFPs?
- Who wants to bid on any of these topics?
- Form groups:
  - Round 1: Group 1 works on RFPs X and Y and Group 2 works on RFPs A and B
  - Round 2: Group 1 works on RFPs A and B and Group 2 works on RFPs X and Y
  - If conflicted: Work on RFP elements for other priority areas

# NEXT STEPS: RFP ELEMENTS

## ***Problem statement (High priority)***

- What is the problem/knowledge gap establishing this research need?
- Why is this a problem?
- Any historic information is welcome, but not needed

## ***Existing Data and Information (Lowest priority)***

- If you know this, or even parts of it, work on adding this last

## ***Study Objectives (High priority)***

- What this work needs to accomplish – the objective is to complete a study of..., to provide values for...
- Feel free to use charge questions or question format – the objective is to answer the following questions....

## ***Expected Outputs and Outcomes (High priority)***

- Think of outcomes in terms of a vision – “coming out of this research, we will have/know.....”
- Outputs are the deliverables – actual things, material not visionary

## ***Tasks (Medium priority)***

- How you might break this work into tasks – what types of approaches/methods/steps you would want someone to take
- Proposers will also be asked to provide an approach – but any minimum requirements/examples would help



## MECHANISTIC MODELS DISCUSSION

Utah Lake Water Quality Study  
Science Panel Meeting  
March 19-20, 2020  
Salt Lake City, UT

# MECHANISTIC MODEL TASK SCOPING

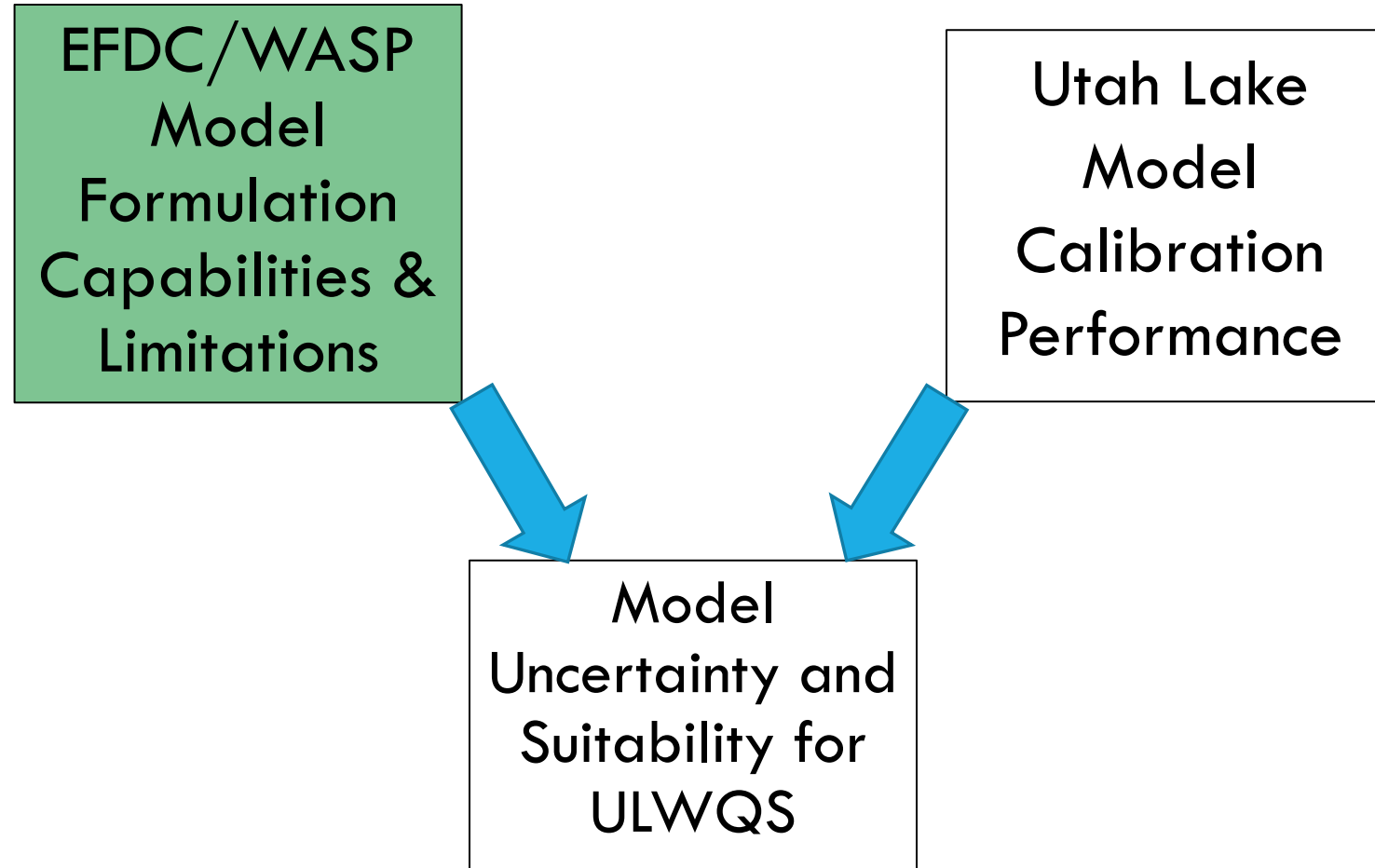

# CONCEPTUAL MODEL ELEMENTS REPRESENTATION IN MECHANISTIC MODELS

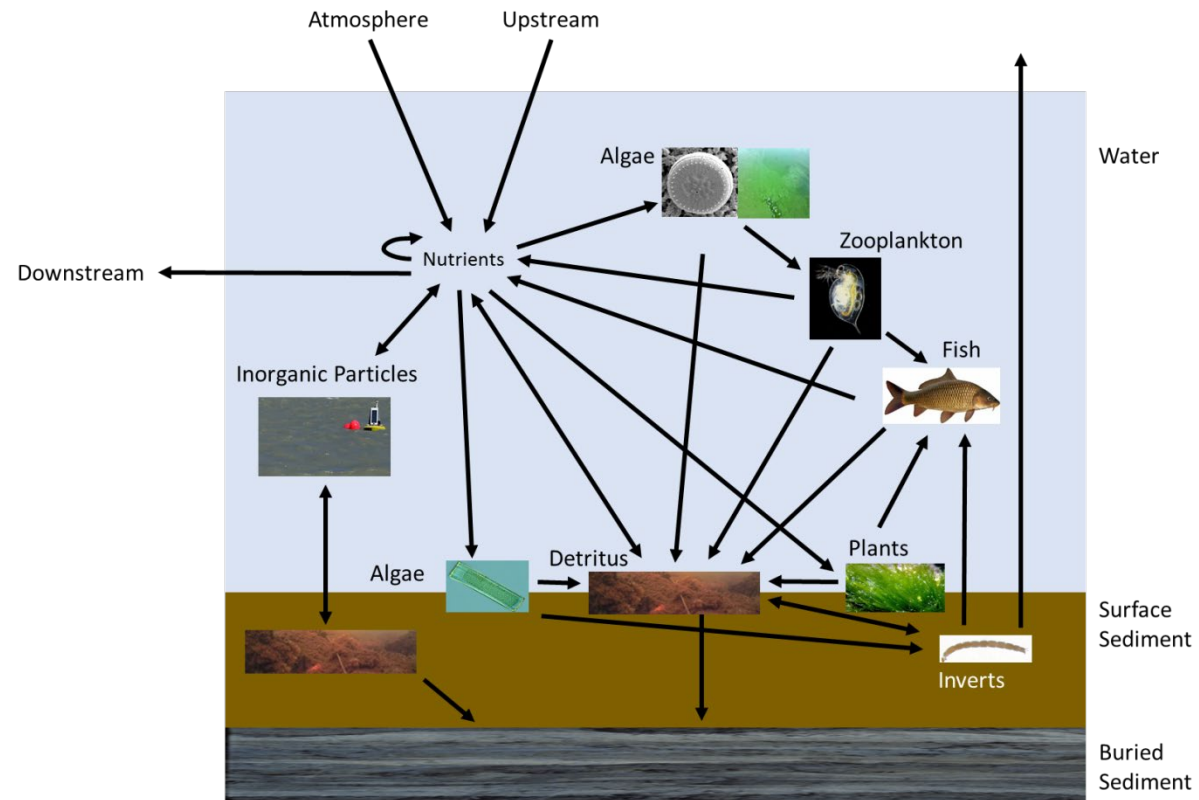

Figure . Simplified nutrient model

# FROM DECEMBER, 2019 SP MEETING

- Juhn-Yuan Su (Univ. of Utah) and Nick von Stackelberg (UDWQ) identified components of conceptual models that are in water quality models
- This was clarified in the updated document (version 5), which you have.
- Reviewed conceptual models with Steering Committee – no major issues/questions really

## 1.0 MECHANISTIC MODELING COMPARISON

Model engineers and scientists working at the University of Utah (Juhn-Yuan Su) and UDWQ (Nick Von Stackelberg) were asked to review the models above for those components that are simulated or not simulated by the mechanistic models. This section briefly highlights the feedback from those technical experts.

### 1.1 CAUSAL MODEL

The following elements of the causal model are not simulated in WASP or EFDC

#### Modifying Factors

- Turbidity: This parameter is currently not incorporated in this version as a state variable and hence is not modeled in WASP. Since WASP does not simulate turbidity, WASP will not simulate the effects of phytoplankton upon water clarity. However, EFDC does simulate classes of inorganic suspended sediment which can be used to simulate turbidity.
- Food Web: WASP is not implemented as a food web model and hence does not incorporate any food web processes nor any aquatic life or wildlife response explicitly.

#### Path Steps/Assessment Endpoints

- Inorganic Particulate N and P: WASP simulates the dissolved inorganic species (N and P). Inorganic Particulate N and P is incorporated in WASP through the simulation of benthic N and P rates under the sediment diagenesis routine. WASP does NOT simulate particulate inorganic N and P as separate state variables.
- Other Parameters: WASP does not simulate changes in food resources and habitat structure nor any changes in competition outside of nutrient uptake kinetics. Similarly, taste and odor or scums are not simulated directly.

Meanwhile, the following components can be represented in WASP but may exhibit significant limitations.

#### Modifying Factors

- Grazing: WASP incorporates grazing characteristics through the palatability of each phytoplankton group. WASP does not incorporate other grazing processes.

#### Path Steps/Assessment Endpoints

- Change in N and P in subsurface waters: WASP can incorporate groundwater inflow quantity and quality into the Utah Lake model, which currently includes 4 groundwater sources (Northern Valley, Southern Valley, Provo Bay, Goshen Bay). On the other hand, such groundwater inflows serve as inputs into WASP and are not simulated separately as no groundwater models have been applied.
- Algal Toxins: WASP only simulates the concentrations of phytoplankton and algae and does not simulate toxins.



Causal model

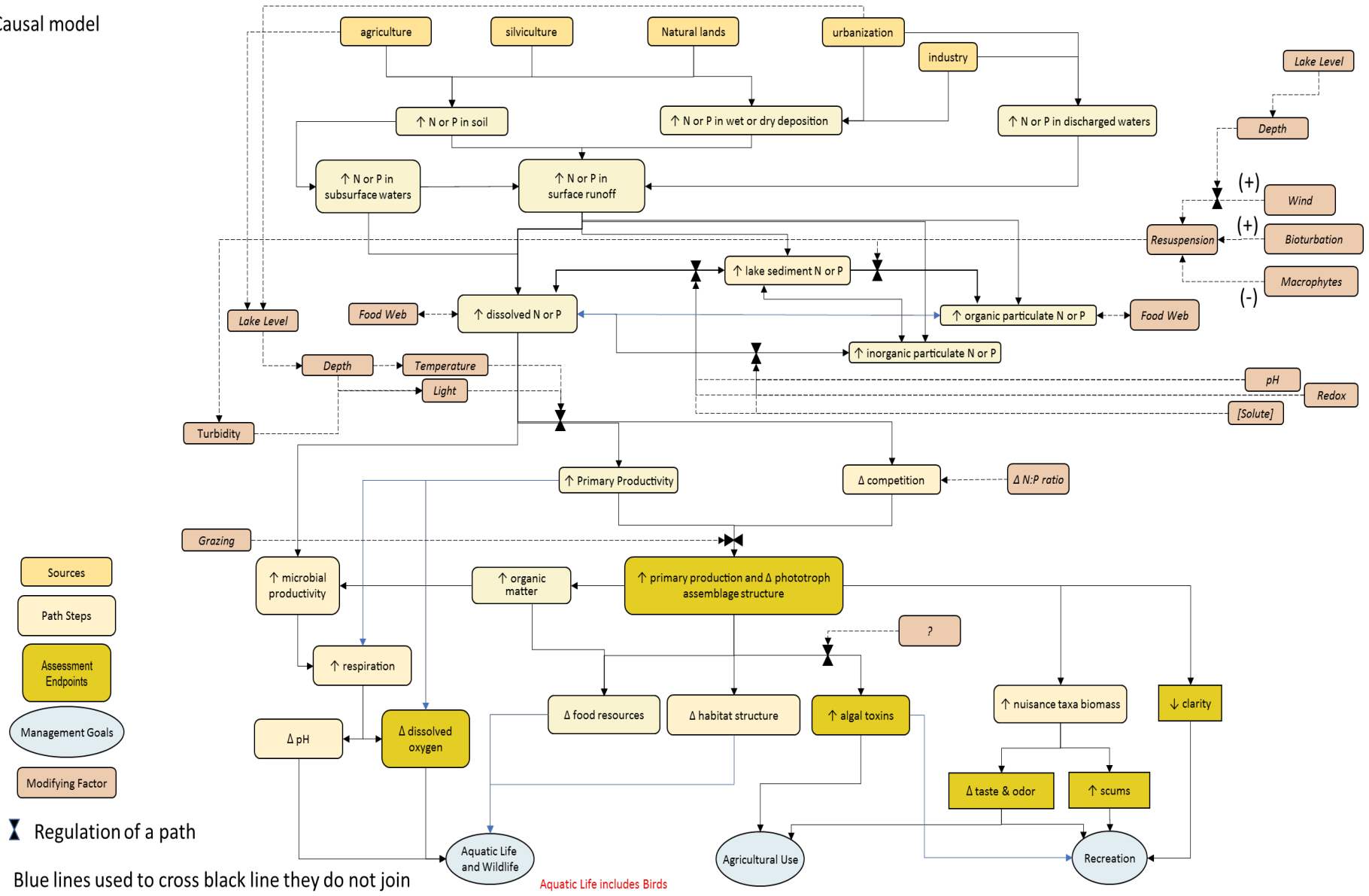

X Regulation of a path

Blue lines used to cross black line they do not join

Aquatic Life includes Birds

Causal model

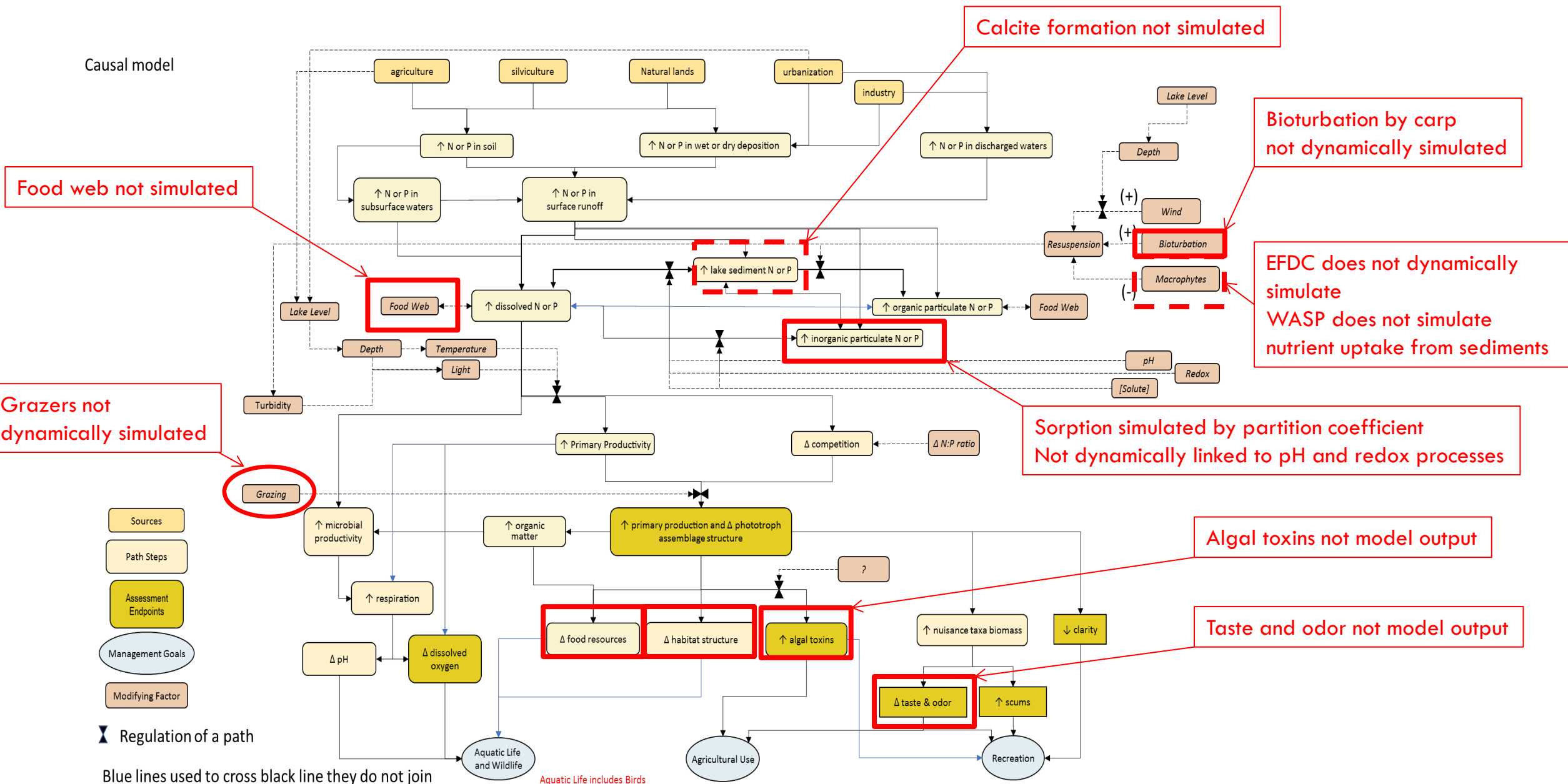

Food web not simulated

Calcite formation not simulated

Bioturbation by carp not dynamically simulated

EFDC does not dynamically simulate  
WASP does not simulate nutrient uptake from sediments

Grazers not dynamically simulated

Sorption simulated by partition coefficient  
Not dynamically linked to pH and redox processes

Algal toxins not model output

Taste and odor not model output

X Regulation of a path

Blue lines used to cross black line they do not join

Aquatic Life includes Birds

# Phosphorus Model

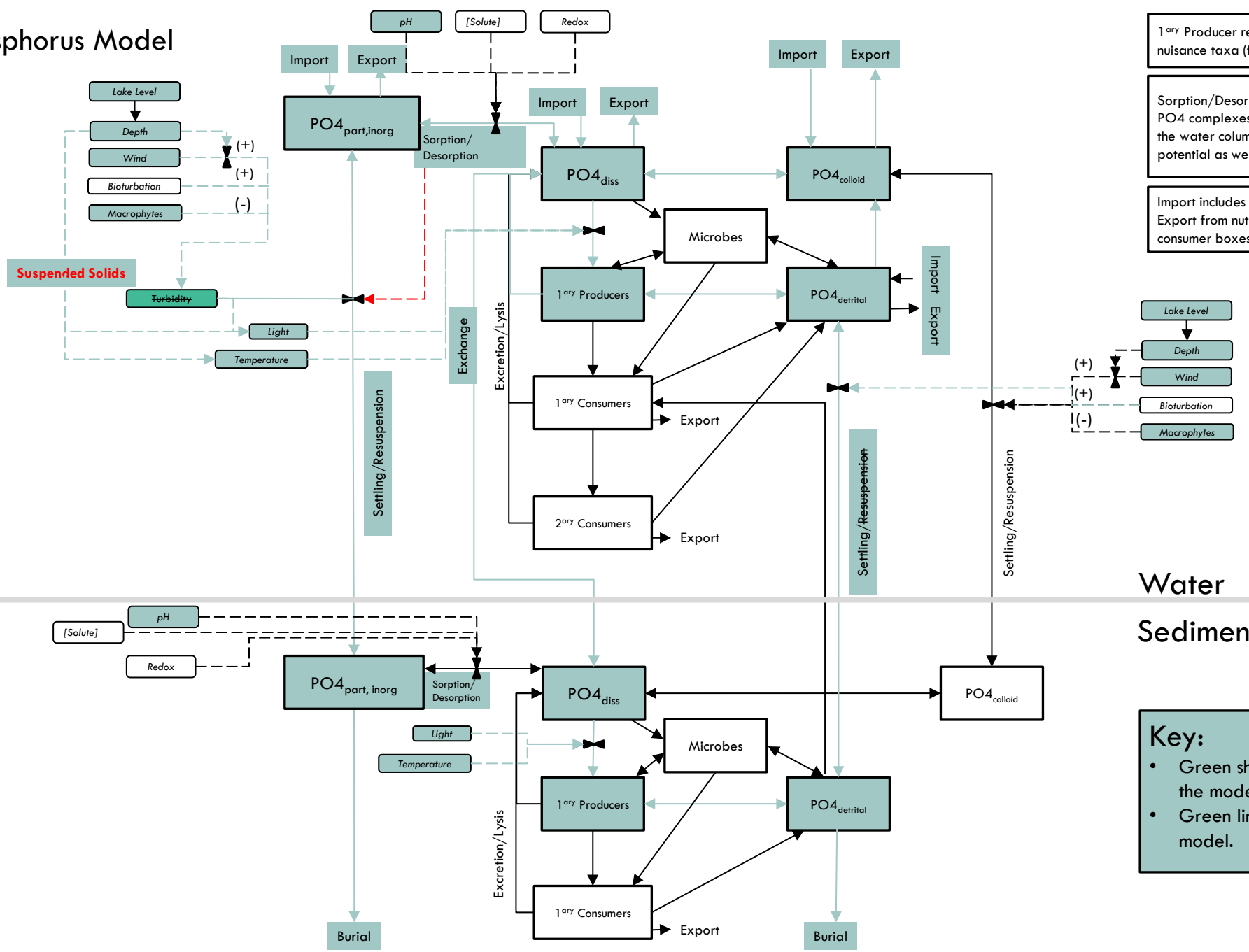

1<sup>ary</sup> Producer responses included shifts in species composition including to nuisance taxa (from competitive shifts) as well as increased biomass.

Sorption/Desorption includes calcite scavenging, formation of iron or aluminum-PO4 complexes, and other chemical complexation reactions of ions with PO4 in the water column or sediment influenced by pH and reduction/oxidation potential as well as by these ion concentrations in the water or sediment.

Import includes tributary as well as atmospheric wet and dry deposition; Export from nutrient pools is largely downstream transport; Export from consumer boxes is emergence/harvest.

Water  
Sediment

**Key:**

- Green shading indicates constituent is represented in the model.
- Green line indicates process is represented in the model.

# Nitrogen Model

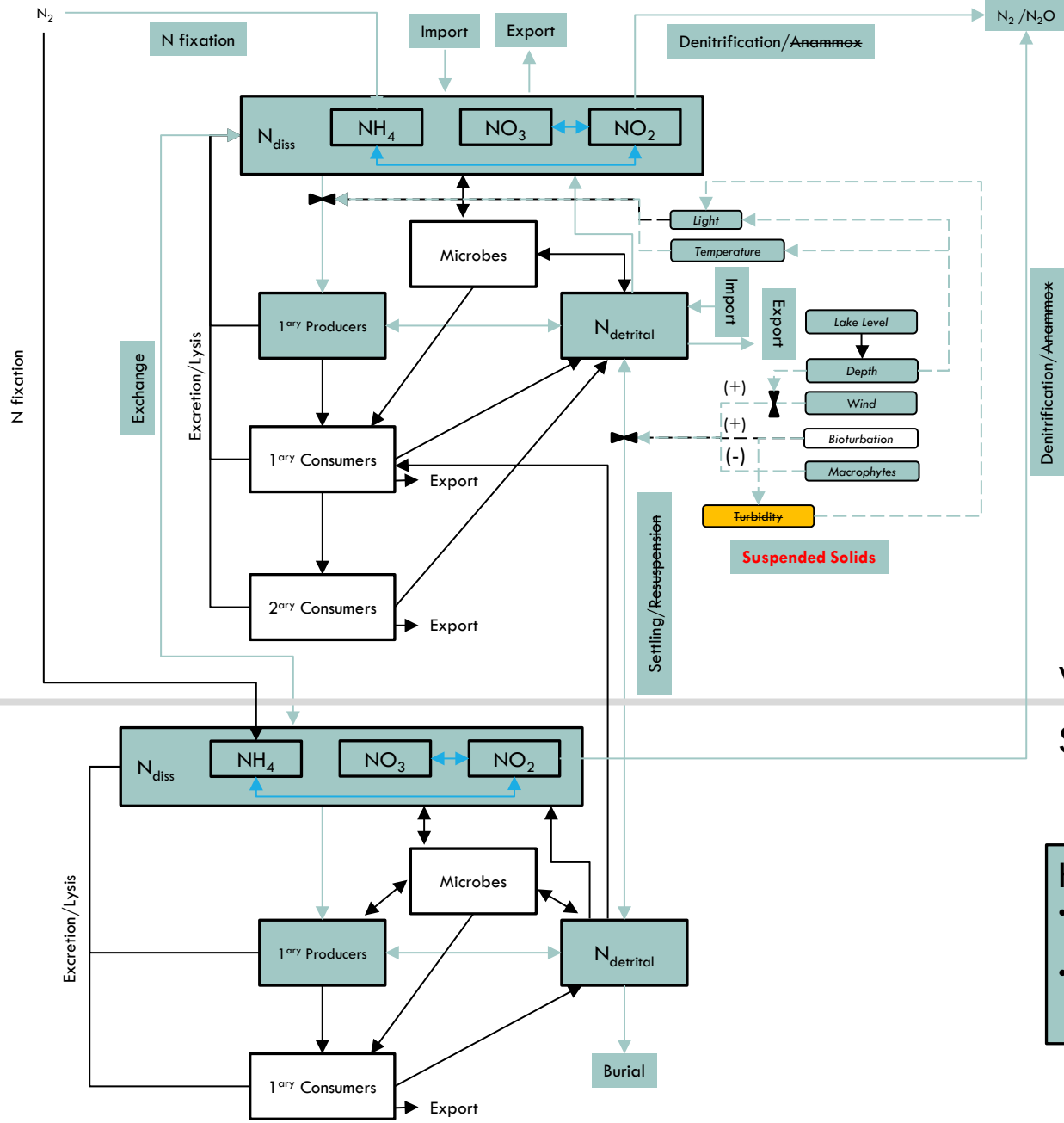

1<sup>ary</sup> Producer responses included shifts in species composition including to nuisance taxa (from competitive shifts) as well as increased biomass.

Blue arrows in N<sub>diss</sub> include several microbially mediated N transformations.

Import includes tributary as well as atmospheric wet and dry deposition; Export from nutrient pools is largely downstream transport; Export from consumer boxes is emergence/harvest.

Reactions within the N<sub>diss</sub> box including nitrification (ammonium oxidation and nitrite oxidation) and nitrate/nitrite reduction

Water  
Sediment

**Key:**

- Green shading indicates constituent is represented in the model.
- Green line indicates process is represented in the model.

# UTAH LAKE EFDC-WASP STATE VARIABLES (WATER COLUMN)

## EFDC

### Flow

- Depth
- Velocity
- Shear Stress

### Water Temperature

### \*Inorganic Solids (3 classes)

\* *Constituent not output to WASP*

## WASP

Ammonia [ $\text{NH}_3 / \text{NH}_4^+$ ]

Nitrate [ $\text{NO}_2^- + \text{NO}_3^-$ ]

Dissolved Inorganic Phosphate  
[ $\text{H}_2\text{PO}_4 / \text{HPO}_4^- / \text{PO}_4^{2-}$ ]

Dissolved Oxygen

Solids (3 classes)  
[sand, silt, clay]

*Water Temperature (from WASP)*

*Alkalinity (not implemented)*

*pH (not implemented)*

Phytoplankton (3 classes)

- *Synechococcus*
- *Aphanizomenon Gracile*
- *Microcystis Aeruginosa*

Periphyton/Macroalgae (1 class)

- Non-transported benthic algae

Particulate Organic Matter (POM)

- Particulate Organic Carbon (POC)
- Particulate Organic Nitrogen (PON)
- Particulate Organic Phosphorus (POP)

Dissolved Organic Matter

- CBOD Ultimate (1 class)
- Dissolved Organic Nitrogen (DON)
- Dissolved Organic Phosphorus (DOP)

# SEDIMENT DIAGENESIS IN WASP MODEL

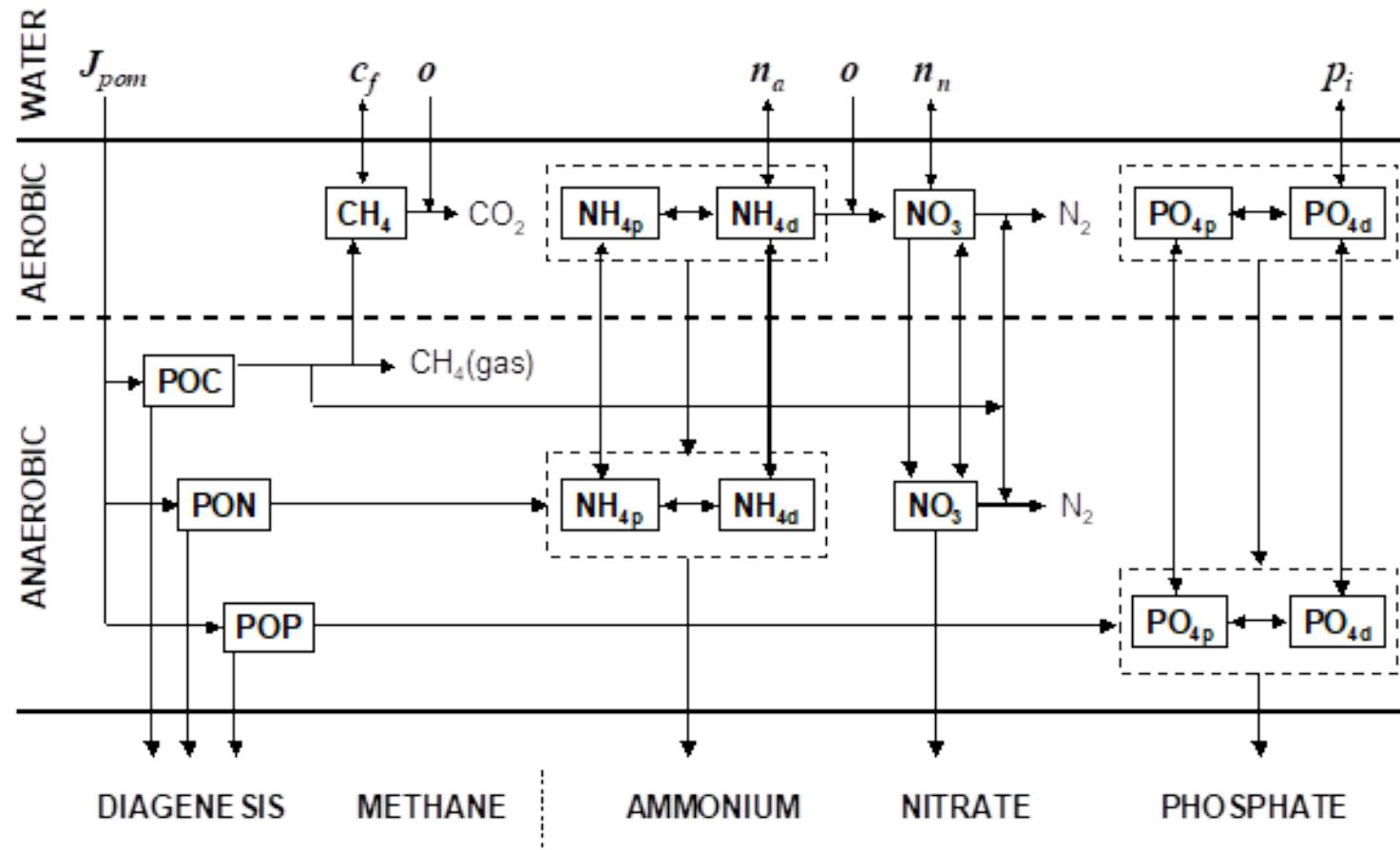

# UTAH LAKE EFDC-WASP SEDIMENT DIAGENESIS IMPLEMENTATION

In current version of WASP:

- Cells are specified where sediment diagenesis is simulated
- One option is applied to ALL selected cells
  - 1) Simulate sediment diagenesis
  - 2) Prescribe SOD/nutrient fluxes
- Significant run times associated with simulating sediment diagenesis on cells that are “dry”
- Subset of “wet” cells selected for Utah Lake model

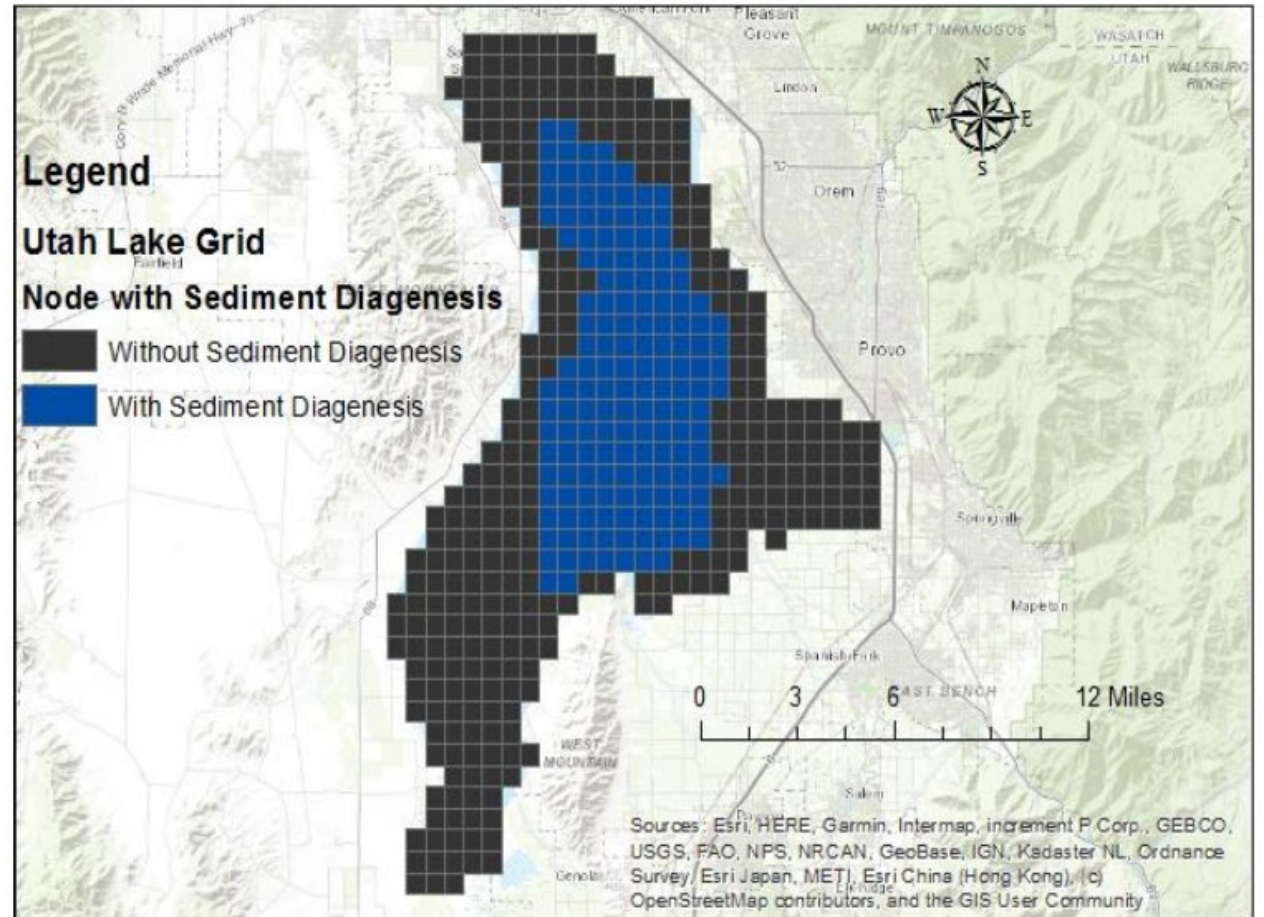

# SUMMARY OF MODEL LIMITATIONS

## 1) Algal Toxins

- Does not simulate algal toxin production, only biomass of phytoplankton groups

## 2) Food Web

- Does not incorporate food web processes, including primary and secondary consumers
- Does not dynamically simulate grazers, only effect on phytoplankton group biomass

## 3) Bioturbation

- Does not simulate sediment resuspension due to benthivorous fish

## 4) Microbial Decomposition

- Does not simulate microbial biomass, only effect of microbes on organic matter decomposition



# SUMMARY OF MODEL LIMITATIONS

## 5) Calcite Formation

- Formation of calcite is not simulated
- Could be assigned a solids class with P sorption

## 6) Phosphorus Sorption

- Sorption/desorption simulated by partition coefficient
- Not dynamically linked to pH and redox processes

## 7) Sediment Diagenesis

- Only simulated on cells “wet” throughout simulation period
- EITHER sediment diagenesis is simulated OR SOD/nutrient flux is prescribed for model

## 8) Macrophytes

- Filamentous benthic algae simulated
- Does not simulate nutrient uptake from sediments



## MECHANISTIC MODELS DISCUSSION

Utah Lake Water Quality Study  
Science Panel Meeting  
March 19-20, 2020  
Salt Lake City, UT

# WASP8 EUTROPHICATION STATE VARIABLES (WATER COLUMN)

Ammonia ( $\text{NH}_3$  /  $\text{NH}_4^+$ )

Nitrate ( $\text{NO}_2^-$  +  $\text{NO}_3^-$ )

Phosphate

( $\text{H}_2\text{PO}_4$  /  $\text{HPO}_4^-$  /  $\text{PO}_4^{2-}$ )

Silicate ( $\text{SiO}_4$ )

DO

Salinity

Alkalinity

TIC

(pH)

Solids (5 classes)

Bacteria (Pathogens, 5 classes)

Tracer (5 classes)

Phytoplankton (10 classes)

- Biomass D:C:N:P:Si:Chl

Periphyton/Macroalgae (5 classes)

- Biomass D:C:Chl
- Nitrogen
- Phosphorus

Particulate Detritus

- POM
- POC
- PON
- POP
- POSi

Dissolved Organic Matter

- CBOD (5 classes)
- DON
- DOP
- DOSi

# UTAH LAKE EFDC-WASP STATE VARIABLES (WATER COLUMN)

## EFDC

### Flow

- Depth
- Velocity
- Shear Stress

### Water Temperature

### \*Inorganic Solids (3 classes)

\* *Constituent not output to WASP*

## WASP

Ammonia [ $\text{NH}_3 / \text{NH}_4^+$ ]

Nitrate [ $\text{NO}_2^- + \text{NO}_3^-$ ]

Dissolved Inorganic Phosphate  
[ $\text{H}_2\text{PO}_4 / \text{HPO}_4^- / \text{PO}_4^{2-}$ ]

Dissolved Oxygen

Solids (3 classes)  
[sand, silt, clay]

*Water Temperature (from WASP)*

*Alkalinity (not implemented)*

*pH (not implemented)*

Phytoplankton (3 classes)

- *Synechococcus*
- *Aphanizomenon Gracile*
- *Microcystis Aeruginosa*

Periphyton/Macroalgae (1 class)

- Non-transported benthic algae

Particulate Organic Matter (POM)

- Particulate Organic Carbon (POC)
- Particulate Organic Nitrogen (PON)
- Particulate Organic Phosphorus (POP)

Dissolved Organic Matter

- CBOD Ultimate (1 class)
- Dissolved Organic Nitrogen (DON)
- Dissolved Organic Phosphorus (DOP)

# SEDIMENT DIAGENESIS IN WASP MODEL

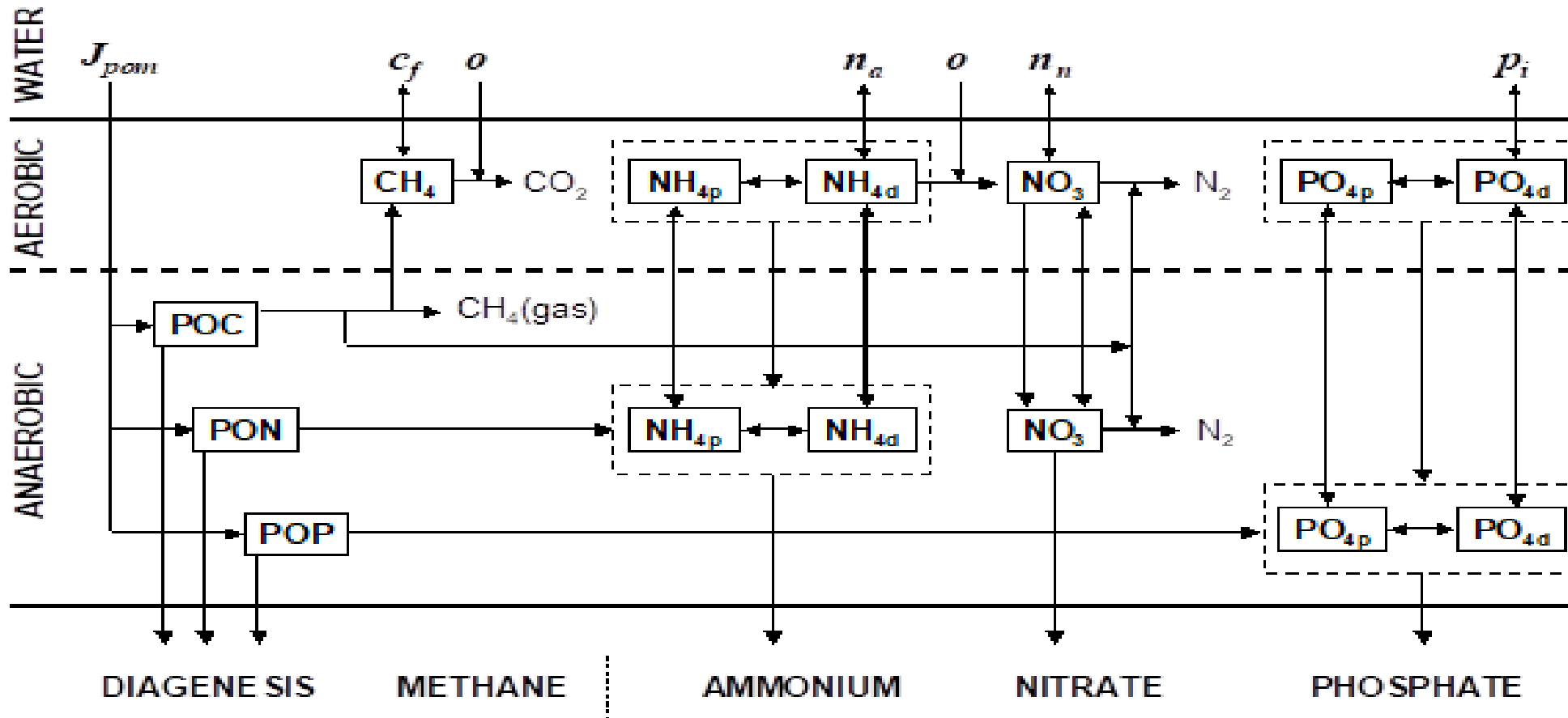

# Nitrogen Model

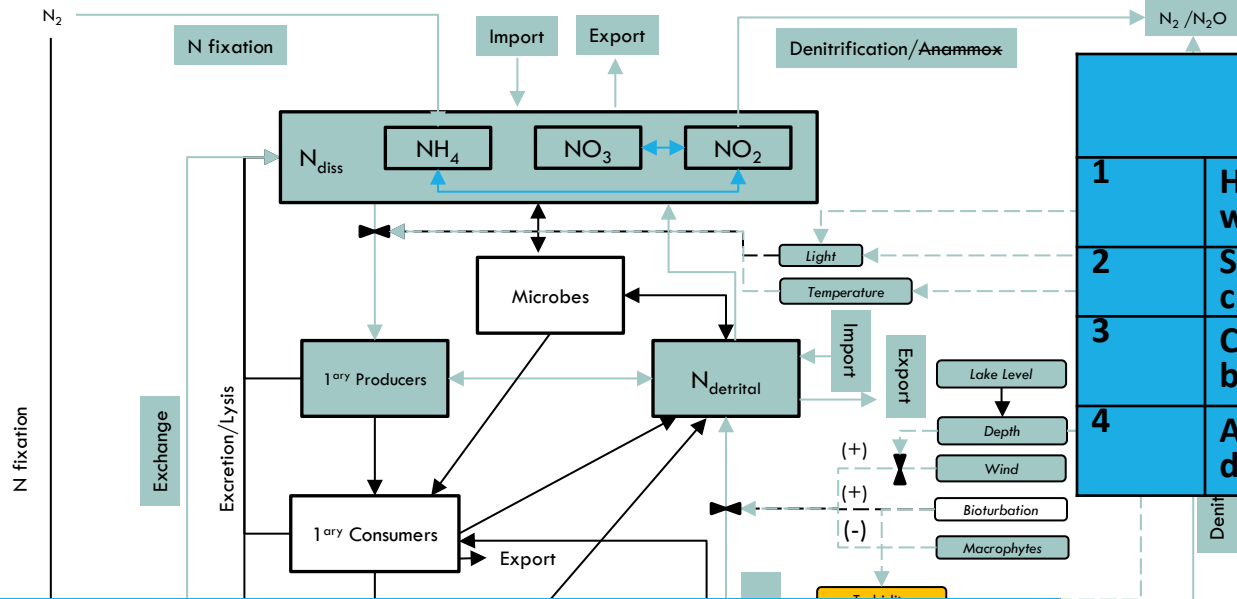

Research ideas	
1	How large is internal vs external loading (how long would recovery take?)
2	Sediment budgets (C, N, and P; nutrient flux chambers)
3	Calcite scavenging (how bioavailable is SRP – does bioassay address?)
4	Adding modules to the WQ models (sediment diagenesis, calcite scavenging)

Priority Questions 1-4 Deal with internal (sediment) loads

Water

Sediment

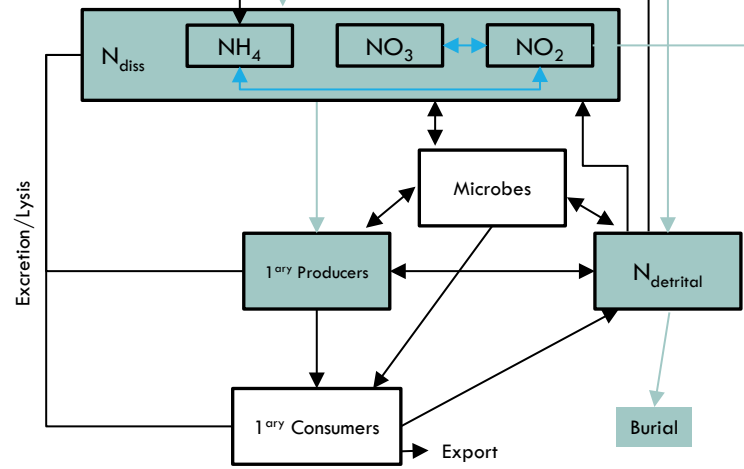

**Key:**

- Green shading indicates constituent is represented in the model.
- Green line indicates process is represented in the model.

# SEDIMENT INTERACTIONS

IS WASP Diagenesis Model Applicable?

- If not, what are the alternatives (describe and input to WASP?)
- How to address model limitations (eg. Fe, Calcite)?

What data are available (and required) to run the diagenesis model and compare predict to observations? Are existing data sufficient and if not what additional studies do we need?

How to use a Sediment Diagenesis Model to address research questions?

- In EFDC/WASP application?
- Are there other approaches which can help address the research questions?
  - in simplified (1-2 Box) model configuration?
  - In another model configuration (LAKE2K)?
  - In a stand-alone application (SEDFLUX)?

(NOTE: All of these use essentially the same diagenesis model and data requirements are the same)

What data are needed to support model and/or address priority questions

- Magnitude of releases
  - Existing data?
  - Models?
- Time rate of change (time of recovery)
  - Data?
  - Microcosm/Mesocosm studies?
  - Models?

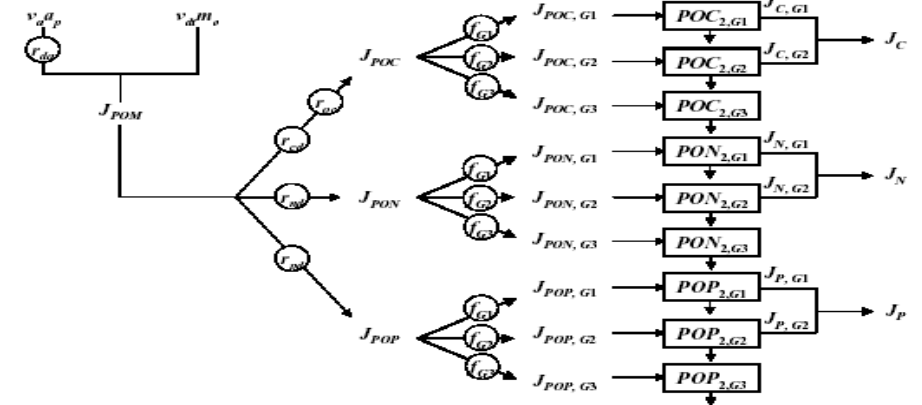

Figure 22 Representation of how settling particulate organic particles (phytoplankton and detritus) are transformed into fluxes of dissolved carbon ( $J_C$ ), nitrogen ( $J_N$ ) and phosphorus ( $J_P$ ) in the anaerobic sediments.

From Chapra Pelletier, 2003.  
QUAL2K User documentation

# INPUTS TO DIAGENESIS MODEL

## INPUTS

POM Fluxes to Sediments

Dissolved Concentrations in Water

Initial Conditions

- POM for each G-class in Layer 2
  - PON(1), PON(2), PON(3)
  - POP(1), POP(2), POP(3)
  - POC(1), POC(2), POC(3)
- Dissolved concentrations (for layers 1 and 2)
  - Dissolved NH<sub>3</sub>
  - NO<sub>2</sub>
  - NO<sub>3</sub>
  - Dissolved PO<sub>4</sub>

## OUTPUTS

Ammonia flux to water column

Nitrate flux to water column

PO<sub>4</sub> flux to water column (mg/m<sup>2</sup>-day)

Aqueous Methane flux to water column

Gas Methane flux to water column

SOD Sediment Oxygen demand

Sulfide flux to water column

Dissolved (available) silica flux to water column



# CALCITE, INORGANIC PARTICULATE NUTRIENTS

Causal model

**Research ideas**  
**Adding modules to the WQ models (sediment diagenesis, calcite scavenging)**

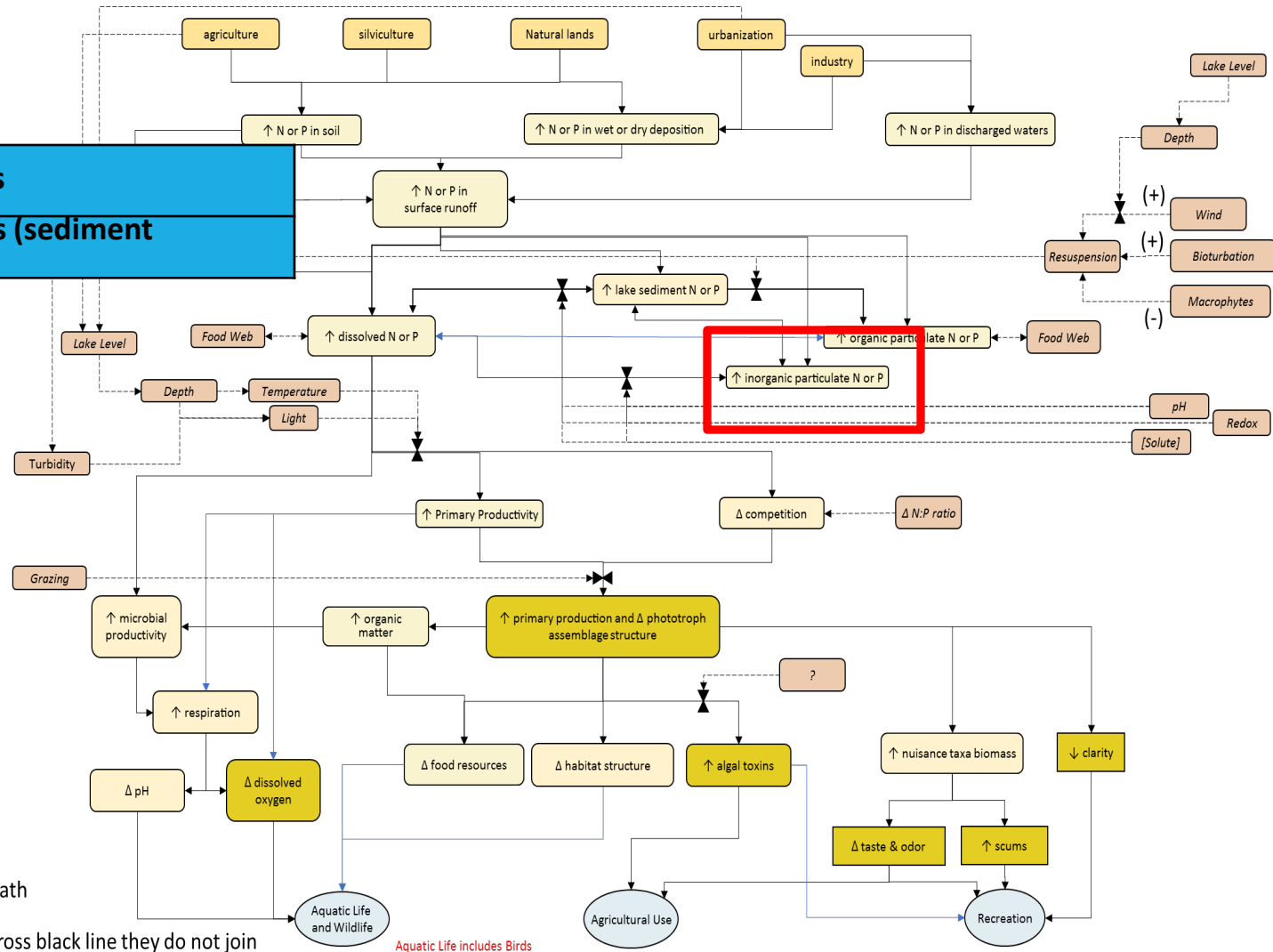

# PRIORITY QUESTION: CALCITE/INORGANIC PARTICULATE NUTRIENTS

## Note in WASP

- data or literature? Need a strategy.
- Describe or predict (and how)?
  - Partitioning relationships?
  - Equilibrium Chemistry?

## WASP INPUT

Constants

Constant Group

Inorganic Nutrient Partitioning

	Constant	System	Used	Value
1	Ammonia Partition Coefficient to Water Column Solids (L/kg)	SOLID 1	<input type="checkbox"/>	0
2	Orthophosphate Partition Coefficient to Water Column Solids (L/kg)	SOLID 1	<input type="checkbox"/>	0
3	Silica Partition Coefficient to Water Column Solids (L/kg)	SOLID 1	<input type="checkbox"/>	0

## Chemical Equilibrium

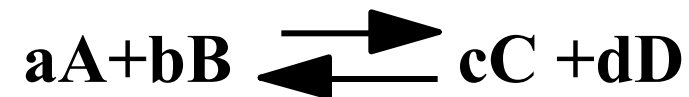
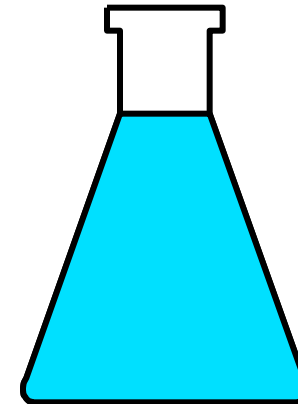

# PRIORITY QUESTIONS: CARP, FOOD CHAIN/WEB

Research ideas	
5	Carp effects on nutrient cycling
12	Resuspension rates from bioturbation
13	Carp effects on zooplankton (and does this influence algal response)
14	Carp effects on macrophytes

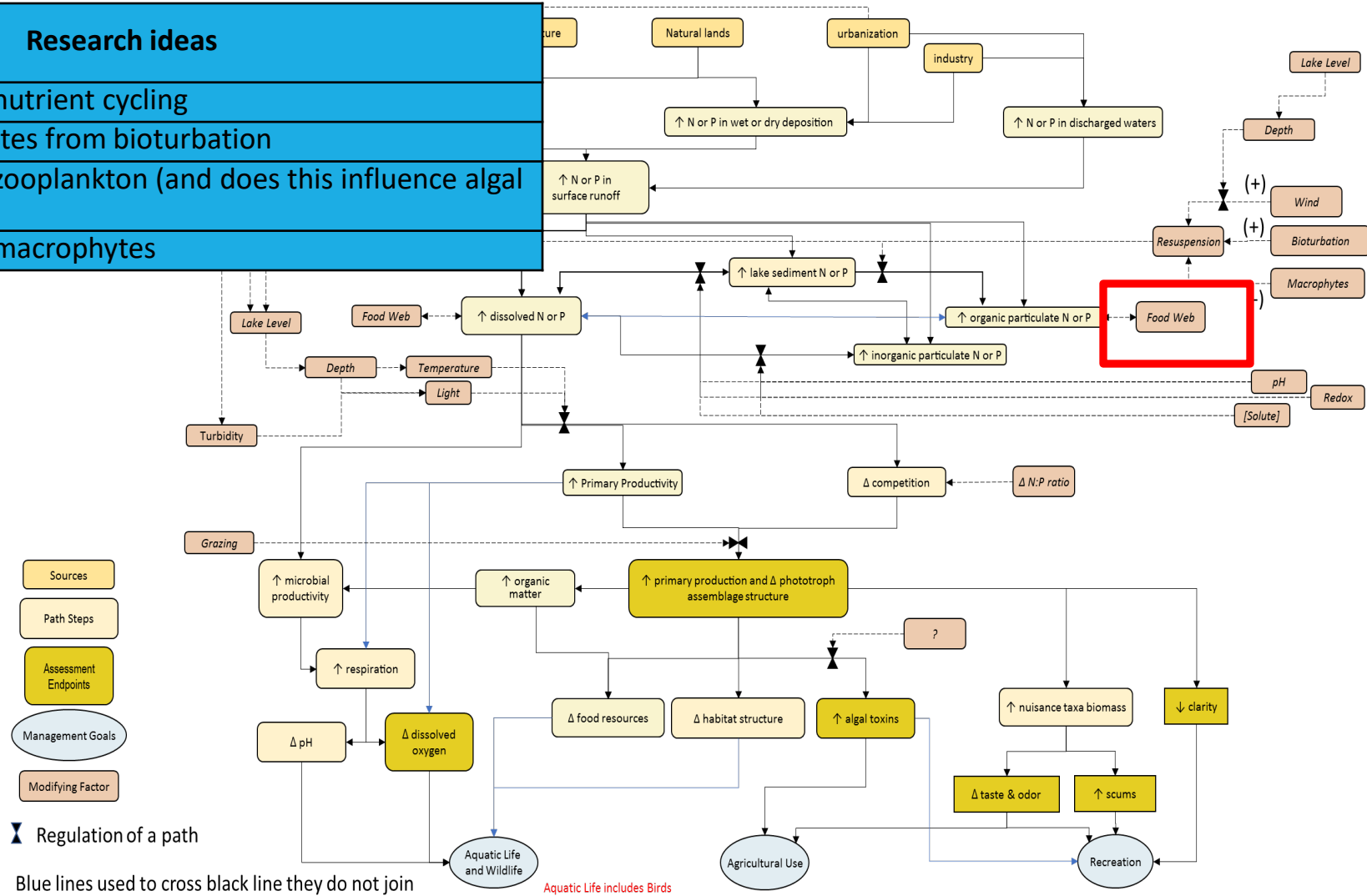

# CARP

App. 4,600,000 Kg (DRY WEIGHT)

(Adults + young (low estimate; Cyprinus carpio Excretion Estimate 20190725))

(assuming 2% P)

92,000 Kg P

REMOVAL

INTAKE

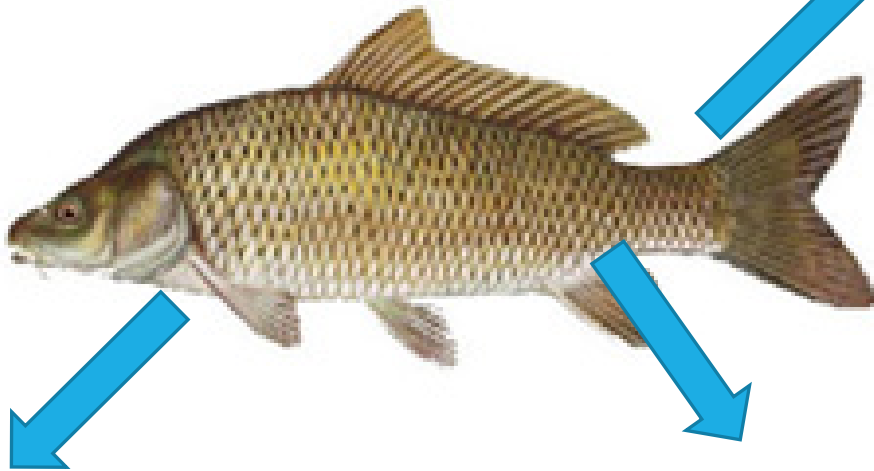

DEATH

EXCRETION

217,490 KgP/yr (Low est.) 620,952 KgP/yr (High est.)



Volume = 747,367,544 m<sup>3</sup> (Average, 2004-2018)

$TP_{avg,UF} = 0.098 \text{ mg/L}$  (Average of 84 ULDB Water Chemistry samples)

=  
73,242 Kg P

**Food Chain/Carp not in WASP:**

- data or literature?
- describe or predict ?
- if Predict, how to model?

# PRIORITY QUESTION 9: LAKE LEVEL

Causal model

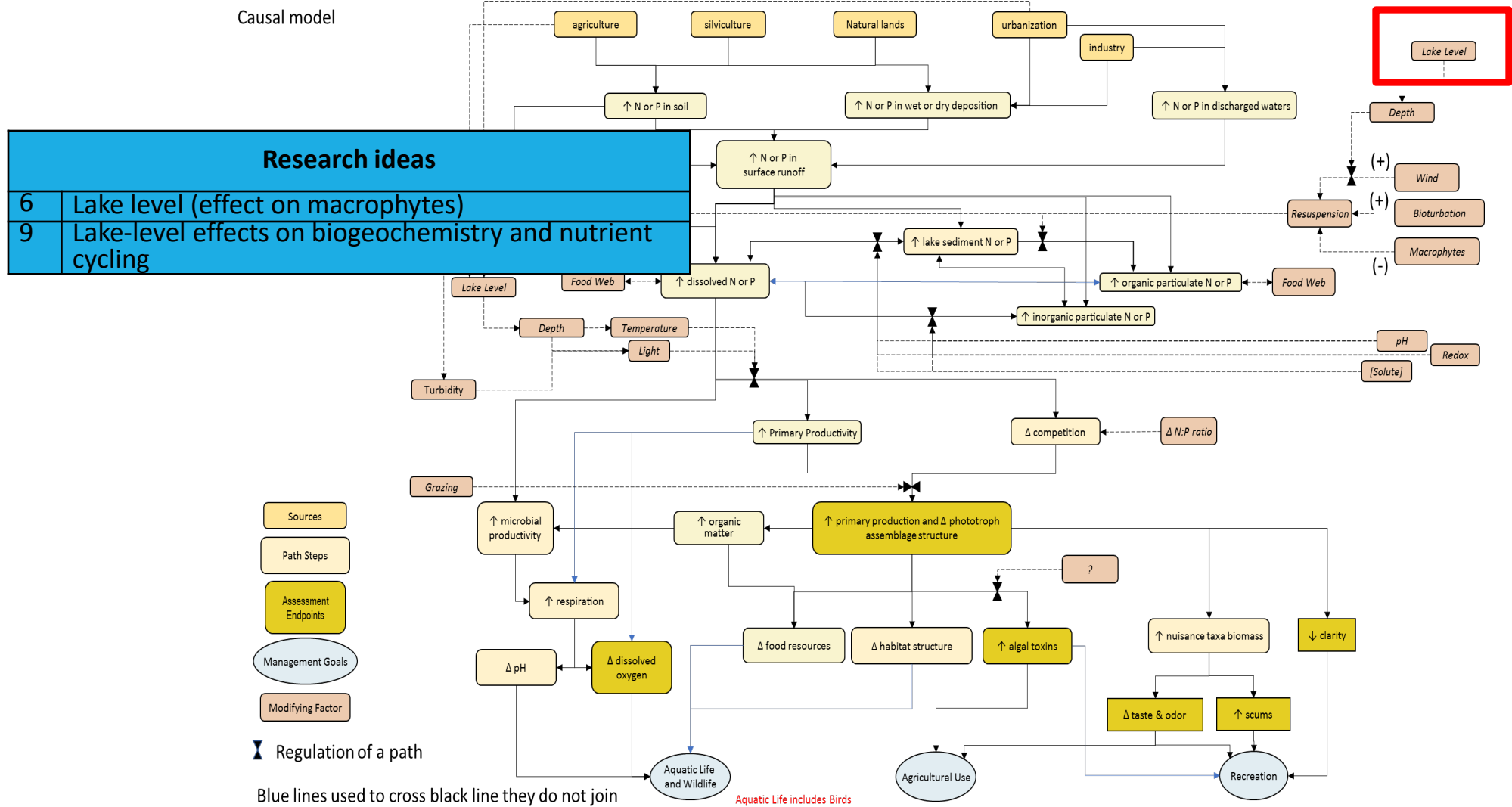

Blue lines used to cross black line they do not join

Aquatic Life includes Birds

## Probability distribution for lake level and surface area

# WETTING/DRYING

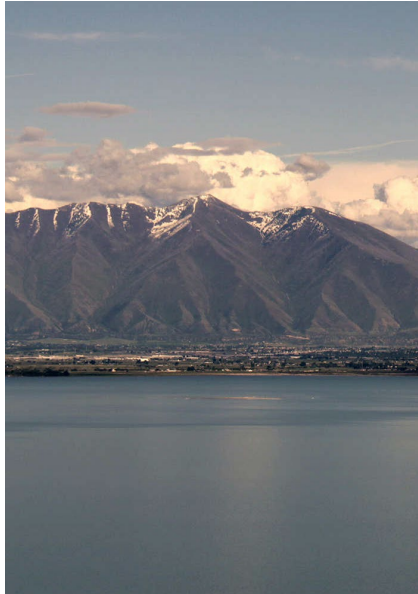

What happens as a result?

- Not modeled in WASP
- (only “ON” or “OFF”)
- Data? Field/Lab studies?

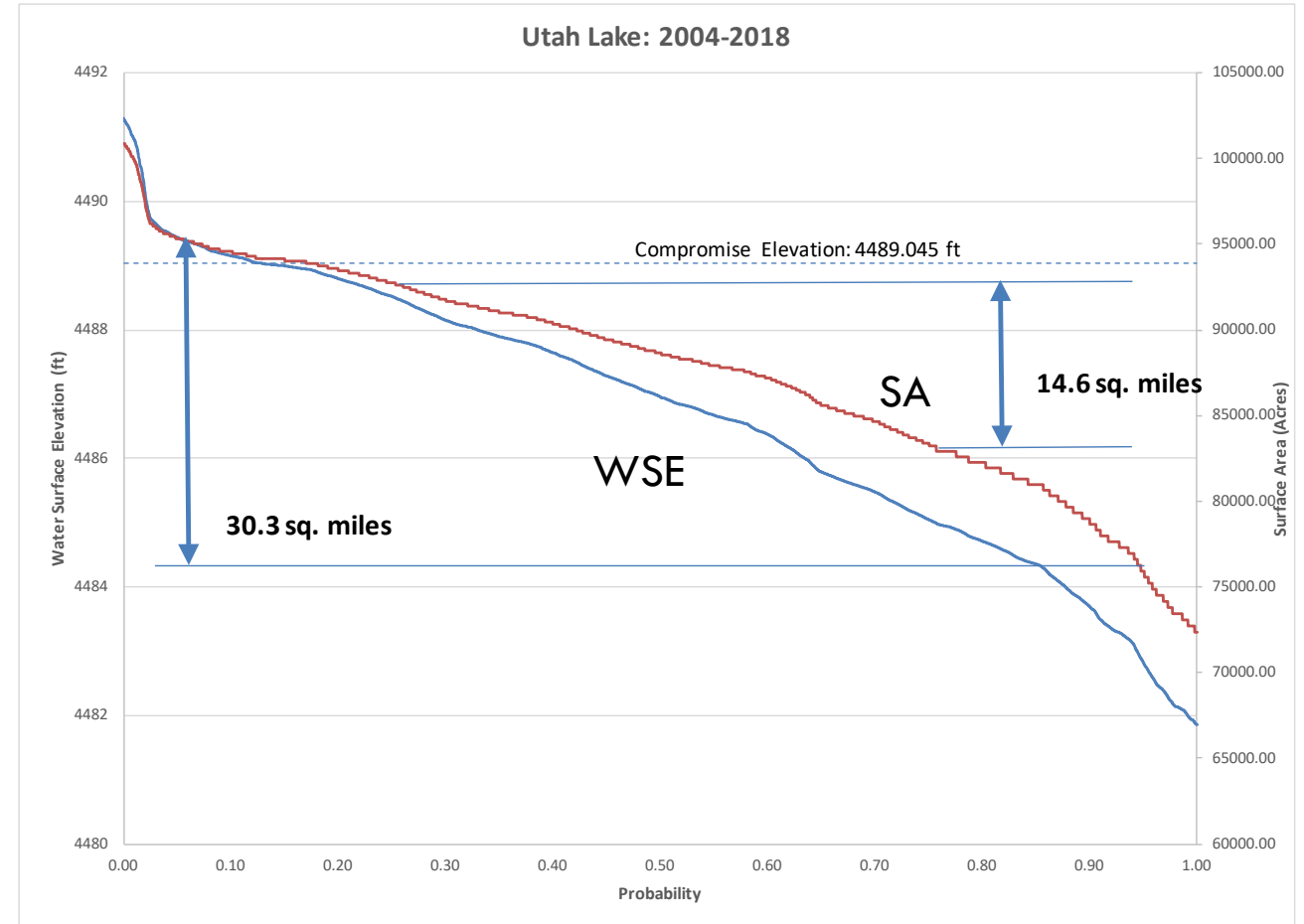

Probability	Elevation (ft)	Area (Ac)	Volume (Ac-ft)
0.95	4482.901	76,301	341,064
0.75	4485.051	83,420	514,677
0.25	4488.551	92,915	821,523
0.05	4489.451	95,482	904,418

# MECHANISTIC MODELS

The WASP being applied (with EFDC) to Utah Lake has a very generalized structure making it applicable to a wide variety of issues and waterbodies

But there are always limitations and there are identified features of Utah Lake that are not represented (In WASP and other models):

- Calcite
- CARP, Food web interactions
- Turbidity
- Wetting/Drying Reactions

Studies are to be developed to further explore these issues prioritized by the SP. But, these new efforts should also be focused on how that information will be used and/or how that information will be incorporated into the existing framework of models (with some limited model modification) and/or other alternative components of the decision making process.

